

UV 100W HAND LAMP

for UV fluorescence

High intensity blacklight for medium area illumination

Product Features

- Compact, lightweight and durable.
- Fan cooled for temperature management.
- 135V to UV hand lamp for added electrical safety.
- Elapsed hour counter for service scheduling.
- Front stand-offs to protect filter
- Stand included with electrical control box.

Options

Power supply requirement:

- 230V/50Hz
- 115V/50Hz
- Switchable 230V/50Hz or 115V/50Hz

Accessories

1. Carrying bag
2. 5m connecting cable extension – UV hand lamp to power supply unit.
3. 10m retractable connecting cable kit – UV hand lamp to power supply unit. Ratchet system with spring return. Requires factory fitting.



1



2



3

Health and Safety

All our UV light equipment is supplied with comprehensive operating instructions - including maximum permissible UV light exposure times for the unprotected skin and eye at specified distances from the UV lamp, enabling strict compliance with new EU rules, defined by the Optical Radiation Directive 2006/25/EC.

Technical Data

- **UV light irradiance** - depends on distance.
- **Illumination area** - depends on distance.
- **Uniformity of UV light irradiance** - depends on illumination area.

The hand lamp incorporates a high intensity discharge 100W mercury UV bulb with spectral output as shown below:

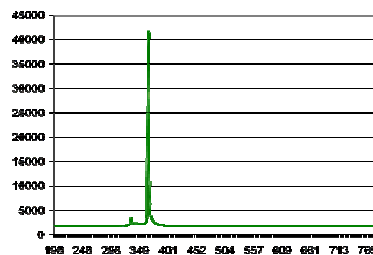

Emission spectrum for 100W mercury UV bulb

A black filter glass with a wavelength transmission range as shown below is fitted in front of the UV bulb in order to produce the required UV light spectral output for UV fluorescent inspection processes.

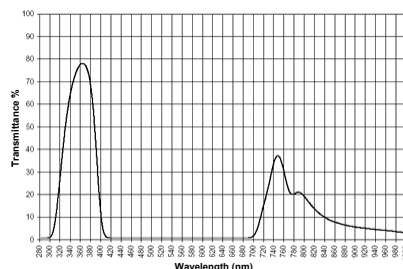

Black filter glass – UV wavelength transmission range 315-405nm

Technical Data (continued)

UV 100W high intensity discharge bulb	Mercury (ozone free)
UV bulb useful operating life (estimated)	500 hours - depends on age, environment, switching and cooling
Filter glass type	Black
Filter glass size	127mm diameter - domed
Reflector	Built in to bulb
Power supply requirement	230V/50Hz or 115V/50Hz
Power	130W
Noise	< 70 dB
Rating	IP 40
Integral fuse protection	2 x 2A miniature time lag fuses - ceramic body 5mm x 20mm
Construction material	Sheet aluminium
Coating material	UV stable black polyester powder
Connecting cable length	3m (5m extension or 10m coiled cable options)
Weight of UV hand lamp	Approximately 1.3Kg

Schematic Drawings

All dimensions in millimetres (mm)
Tolerance +/- 1mm

UV Hand Lamp

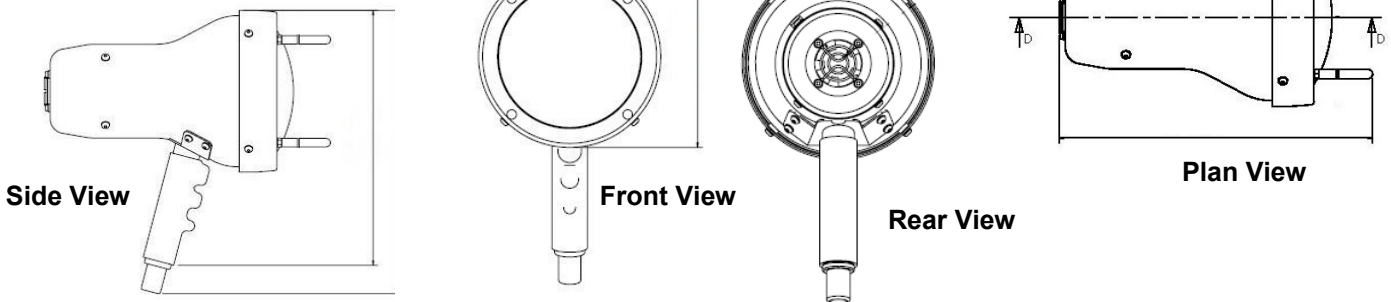

Power Supply Unit

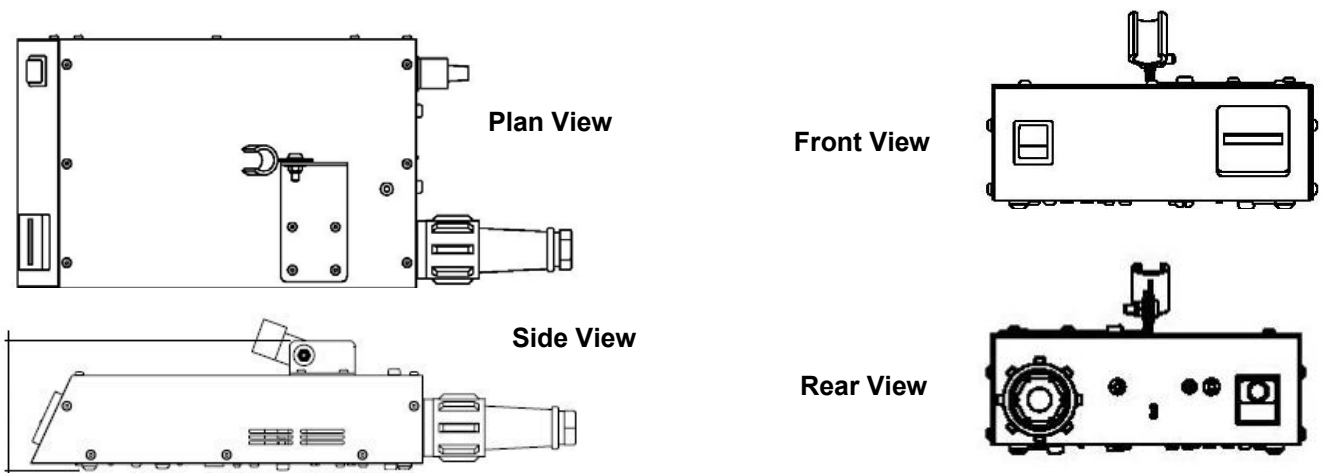

Due to our policy of continual development, we reserve the right to amend technical data.

