

UV-C 400W GERMICIDAL FLOOD LAMP

for UV light disinfection and exposure

Product Features

- High performance.
- Modular design for multiple UV lamp installations.
- Compact, lightweight and durable.
- Fan cooled for temperature management.
- 135V to UV lamp unit for added electrical safety.
- Quartz glass assembly is fitted to a hinged front door, enabling easy access for UV bulb replacement and cleaning.
- Elapsed hour counter for service scheduling.
- Safety wire mesh over quartz glass.
- Mounting bracket.



Accessories

1. Barn doors for restricting UV light beam in certain directions.
2. 5m connecting cable extension - UV lamp unit to power supply unit.



Health and Safety

All our UV light equipment is supplied with comprehensive operating instructions - including maximum permissible UV light exposure times for the unprotected skin and eye at specified distances from the UV lamp, enabling strict compliance with new EU rules, defined by the Optical Radiation Directive 2006/25/EC.

Technical Data

- **UV-C light irradiance** - depends on distance.
- **Illumination area** - depends on distance.
- **Uniformity of UV-C light irradiance** - depends on illumination area.

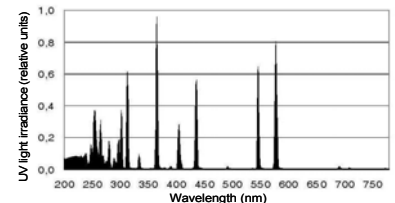

Emission spectrum for mercury UV bulb

Technical Data (continued)

UV 400W high intensity discharge bulb	Mercury (ozone producing)
UV bulb useful operating life (estimated)	500 hours - depends on age, environment, switching and cooling
Quartz glass size	180mm x 140mm x 3.25mm
Reflector	Aluminium - UVL full spectrum grade
Power supply requirement	230V/50Hz or 115V/50Hz (60Hz options available)
Power	410W
Noise	< 70 dB
Rating	IP 40
Integral fuse protection	2 x 6.3A miniature time lag fuses - ceramic body 5mm x 20mm
Thermal protection	Auto reset thermal cut out
Construction material	Sheet aluminium
Coating material	UV stable black polyester powder
Connecting cable length	2m (5m extension option)
Weight of UV lamp unit	Approximately 2Kg

Schematic Drawings

All dimensions in millimetres (mm)
Tolerance +/- 1mm

UV Lamp Unit

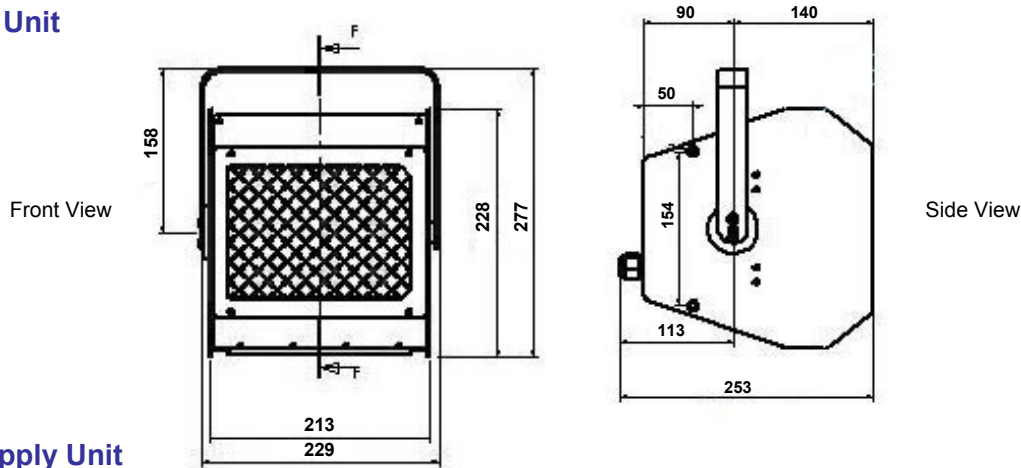

Power Supply Unit

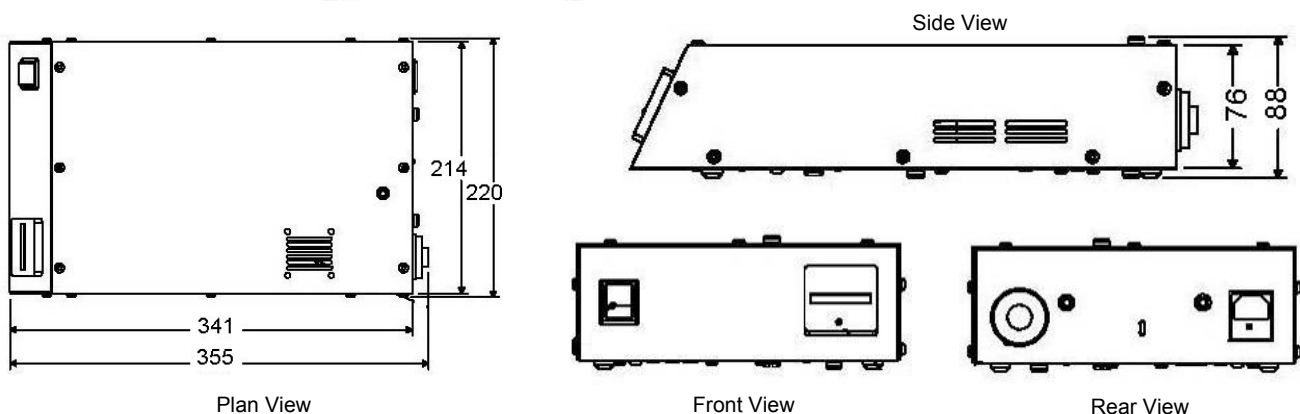

Due to our policy of continual development, we reserve the right to amend technical data.

